

### Features that prolong accurate machine life

- Automatic lubrication system
- One piece cast column with centered elevating screw
- Heat compensating spindle housing
- Direct drive interchangeable spindle
- Hardened and ground screws
- Positive cross feed lock

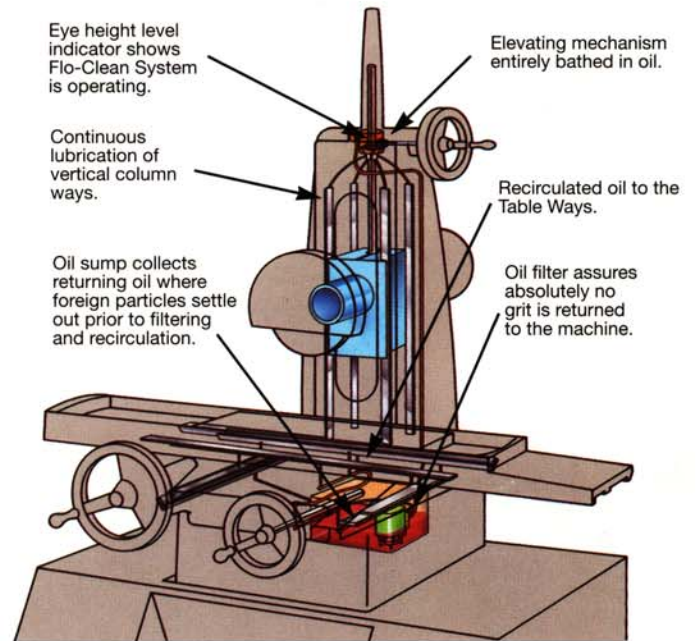

- **Automatic lubrication system:** Most surface grinder oiling systems provide only an occasional shot of oil to the ways. Harig's exclusive Flo-Clean Lubrication System continuously floods ways, bearings, and lead screws with recirculated filtered oil. The system is self contained and completely automatic.

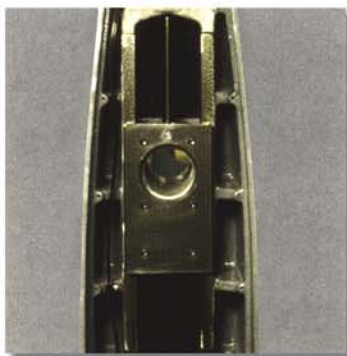

- **One piece cast column with centered elevating screw:** Centrally locating the elevating screw between the column ways minimizes spindle "hang-up."

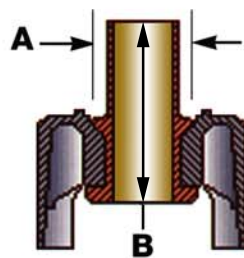

- **Heat compensating spindle housing:** Motor heat causes the spindle housing to expand, destroying the precision fit between the housing column ways. Harig's design maintains this fit regardless of temperature. As dimension (A) expands, dimension (B) expands proportionally, assuring uniform tolerance between the spindle housing and vertical ways.



- **Direct drive interchangeable spindle:** With the removal of the wheel and the guard and loosening five set screws, the cartridge may be slipped out of the back of the machine for easy field replacement.



- **Positive cross feed lock:** Harig's cross feed travel lock clamps to a steel band, not the carriage casting. This prevents any motion induced by tightening the screw from shifting the carriage.



- **Hardened and ground screws:** assure long life and consistent accuracy

# HARIG<sup>®</sup> Accessories

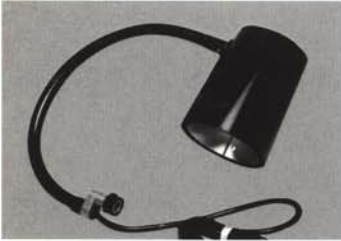

Adjustable work light that's easy to mount.

CODE # 17798100



Walker permanent and electric chuck or Magna-Loc electric magnetic chuck.

CALL FOR DETAILS

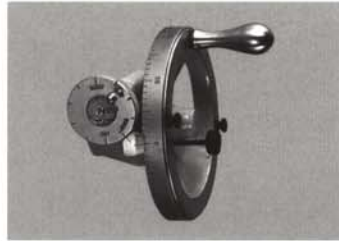

Fine feed handwheel has  $\frac{5}{8}$ " between each .0001" down feed graduation.

CODE # 17111150 INCH  
17111350 METRIC



Hinged table stops, on Hand Feed only, mount to machine in place of standard adjustable stops.

CODE # 16200321



Side unit dust collector with filter bags, hose and intake nozzle.

CODE # 16211352-230/460/360  
16211354-115/230/1/60



Accu-Dresser over-the-wheel straight line dresser mounts permanently on machine.

CODE # 17011200 inch  
17011225 metric



Fine cross feed attachment for applications where extremely accurate cross feed is demanded.

CODE # 17111200 inch  
17111400 metric



Wet grinding package including pump, reservoir and splash guards, necessary hardware and hoses.

CODE # 16211346-612  
16811346-618

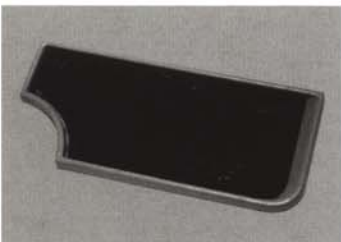

Convenient front mounted tool tray with rubber cushion.

CODE # 16211049



Acu-Rite Quickcount<sup>®</sup> readout can reduce set-up time up to 50%.

CODE # 17111540 Crossfeed  
CODE # 17111545 Downfeed  
CODE # 17111550 Two Axis



Wheel balancer to enable precise balancing of grinding wheels for improved accuracy and life.

CODE # 17794350

■ Ask your Harig salesperson for information on other options and accessories like our cast iron base, speedgrind attachment and diamond dresser.

■ Full support. Harig stands behind every machine with nationwide parts, accessories, service, and application engineering support.

■ Financing and leasing readily available.

# HARIG<sup>®</sup>

Harig Products, Inc. • 1875 Big Timber Road • Elgin, IL 60123 • (847) 695-1000 • Fax: (847) 695-1043

**Safety Notice:** Harig Products, Inc. provides protective devices for the safe use of this equipment. Operation of this equipment may cause injury if the protective devices are removed. A comprehensive safety manual is provided with all machines offered by Harig Products, Inc. and recommended safe operating procedures must be adhered to.